

Premier spherical
roller bearings:
our vast experience

Premier



Industry





All you need to know
about SNR Premier
spherical roller bearings

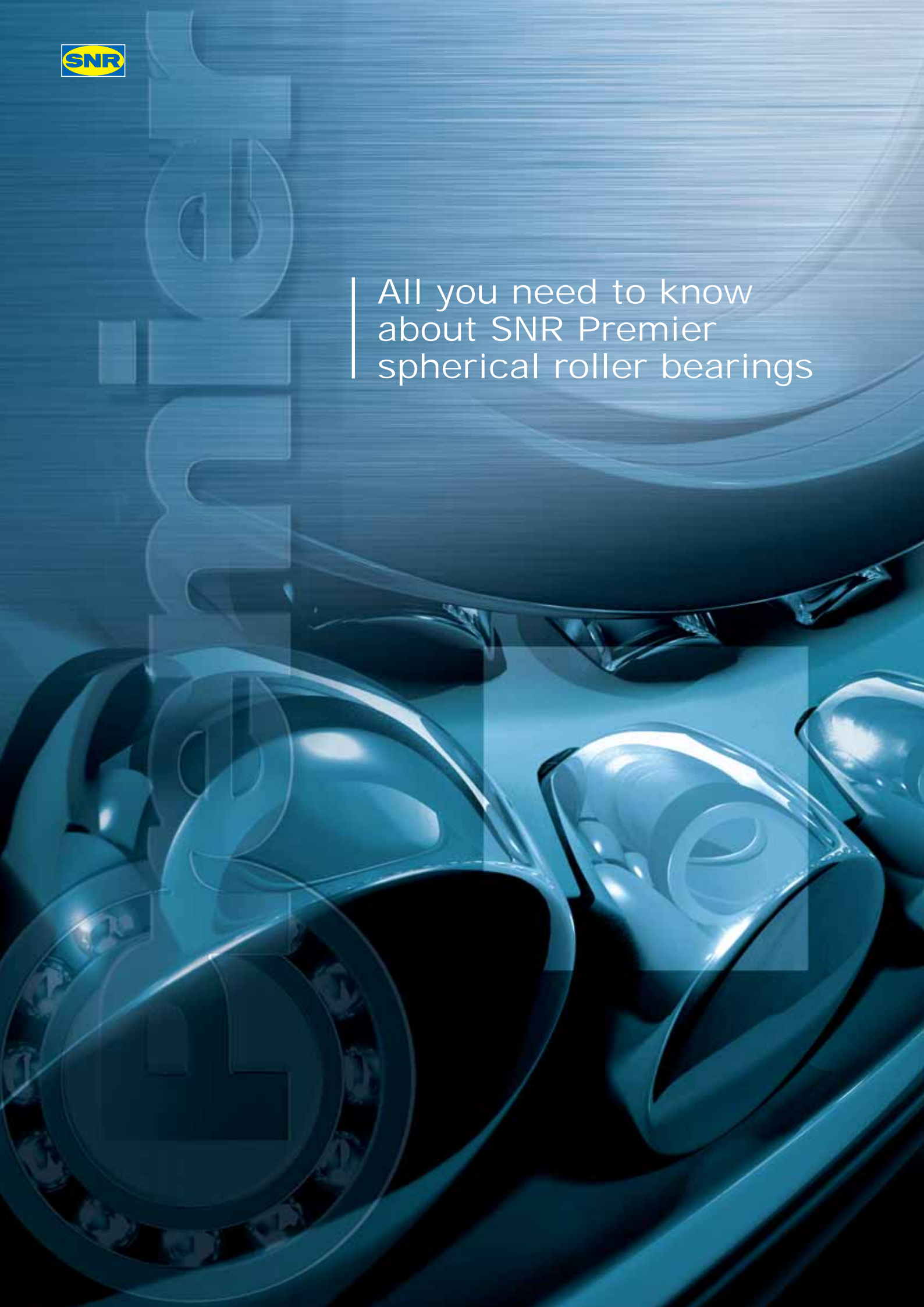

Summary

Premier: more than a product range - a leading manufacturer's philosophy	2-3
Performance and sizes available	4-5
Materials and treatments	6-7
Design, tests and manufacturing means	8-9
Cages	10-13
Lubrication	14-15
Speeds	16-17
Technical information: fundamentals	18-21
Designations, suffixes	22
Range	23-27
Sleeves	28-33
Maintenance	
- Installation - Removal	34
- Lubrication	35
- Monitoring, Services	36-37



Premier: more than a product range - a leading manufacturer's philosophy

Optimize each product to achieve the greatest performance possible, without increasing prices: this is our manufacturing philosophy.

This approach is especially obvious with the Premier line. It consists of providing the highest level of reliability as a standard. This high product quality is supported by our experienced staff, in order to propose the most efficient solutions for your productivity.

The SNR spherical roller bearings are the first to benefit by the Premier approach.



Bearings designed to bear the unbearable

Spherical roller bearings are dedicated to extremely severe applications, such as heavy industries like iron & steel, paper mills, quarries... etc.

They support high loads, severe misalignment, contaminated environments, shocks, and vibrations. These conditions demand exceptional mechanical qualities.



Highly significant improvements

During the last few years, the SNR engineers and researchers have dedicated themselves to material selection, product design, bearing kinematics, manufacturing processes... leading to an outstanding result.

As first beneficiaries of the Premier technology, the SNR spherical roller bearings demonstrate **an 18 % load capacity increase and a service life extension of at least 75 %**.

SNR proposes more reliable, higher performance bearings with unrivalled quality/price ratio.





A product range as exemplary as its performance ratings

The SNR Premier spherical roller bearings have improved in all respects:

- **Increased load capacity, extended service life**, thanks to:
 - very high quality steels, almost free of imperfections.
 - optimized rolling element complement, of maximized profile and quantity. Therefore, their actual service life, as well as dynamic and static load capacities are appreciably higher, for the same envelope dimensions, resulting in:
 - higher reliability of the machines and facilities.
 - use of smaller bearings in new design studies, permitting smaller machines and reduced total costs of the facilities.
- **Reduced friction torque**, as much as 30% less, offering lower operating temperature, with lower power and lubricant consumption.
- Appreciably **increased operating speed**, allowing an extended scope of applications.
- **High temperature capacity up to 200°C (392°F)** for metallic cage bearings. Dimensional stability is ensured by a specific heat treatment.
- +/- 0.5° **mis-alignment capability**, without reducing the load capacity, and up to 1°30' in case of low loads.

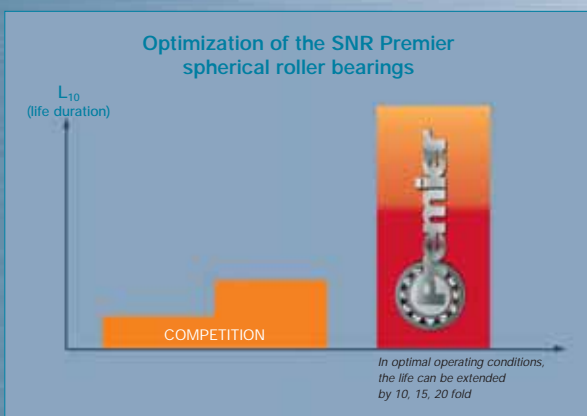

↑ +18%
load capacity.

↑ +75%
minimum service life extension.

Diversified conditions, tailor-made solutions

A spherical roller bearing is not subjected to the same stresses depending on its intended application. The SNR range breaks down into 9 series, each dedicated to specific conditions.

SNR proposes small dimension bearings for high-speed applications: series 23000 and larger section bearings such as series 22300, particularly suitable for high loads.

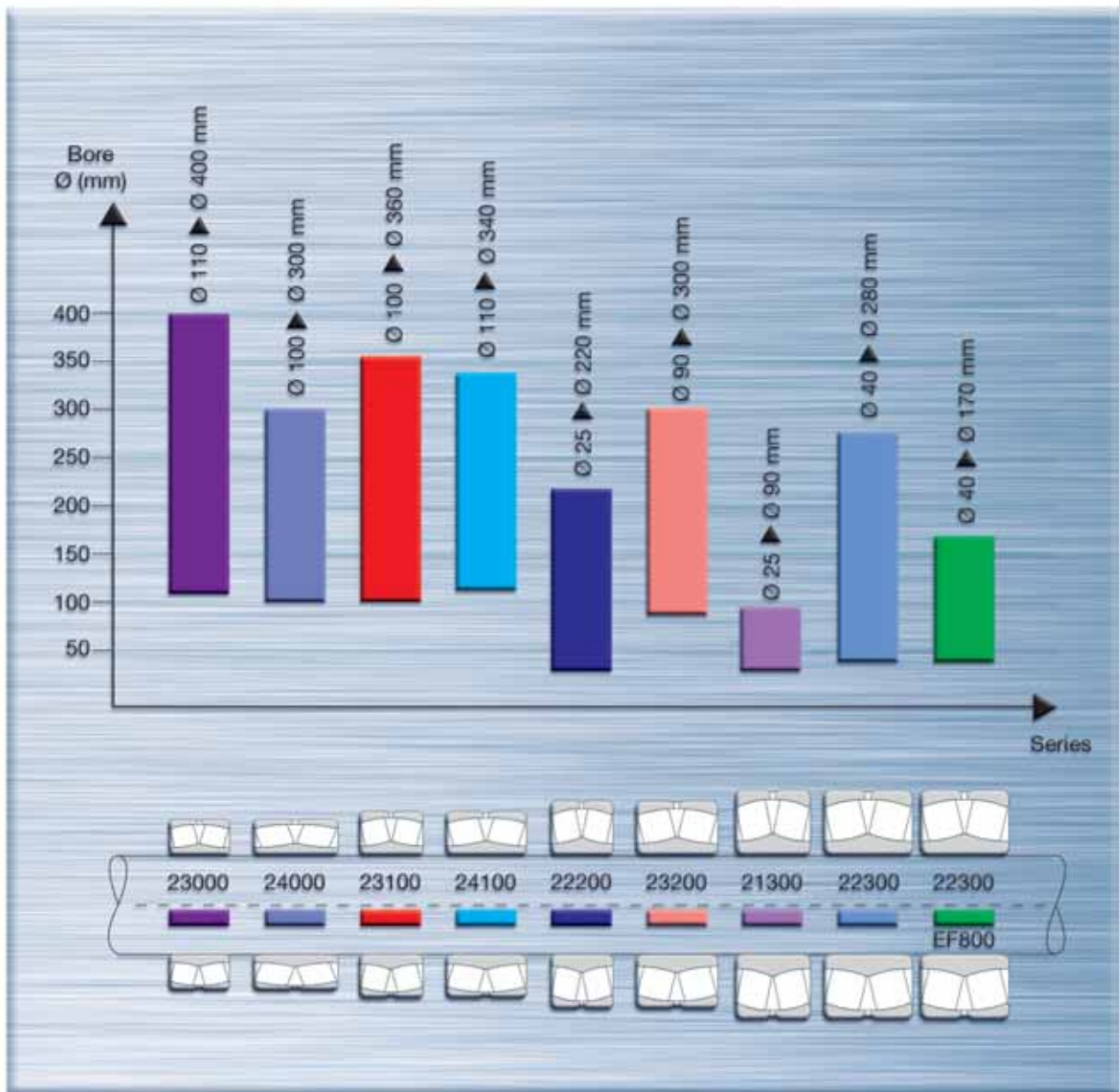

These bearings are also available with reduced and increased internal clearances (C2, C3 and C4), with cylindrical and taper bore (K), glass fiber - filled polyamide cage (G15), steel cage (A) and solid brass cage (M), with lubrication groove (W33). The series EF800 were created to meet the particularly severe requirements of vibratory mechanisms.



From casting to surface treatment: total steel control

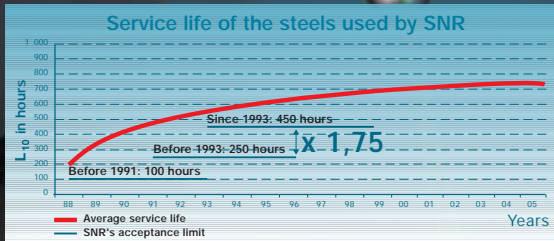
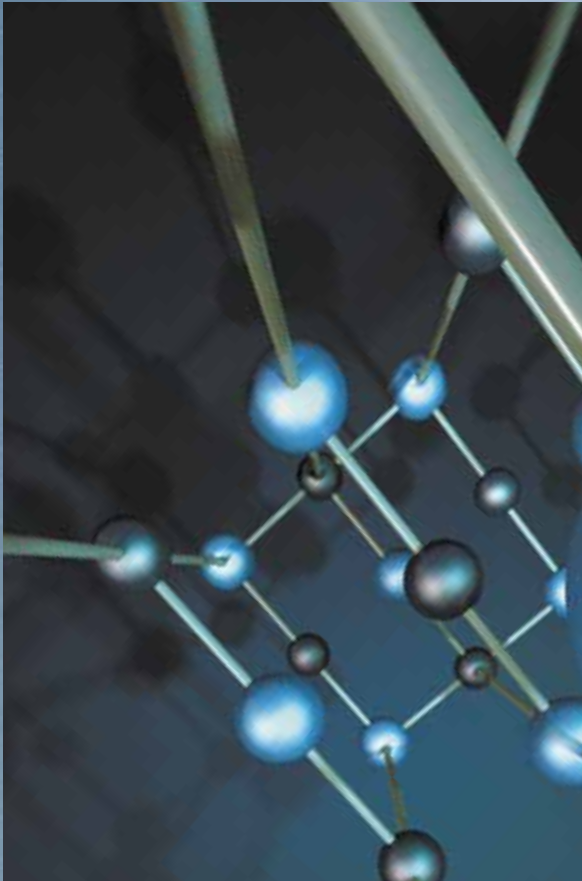

Corrected nominal service life (L_{na})

$$L_{na} = a_1 \cdot a_2 \cdot a_3 \cdot L_{10}$$

a_1 = correction coefficient for a different reliability from 90%.

a_2 = correction coefficient according to material used, internal geometry and bearing manufacture.

a_3 = correction coefficient according to operating conditions (considered equal to 1 in normal operating conditions).

L_{10} = basic nominal life.

Cast quality, alloy purity

To sustain extreme stress loads, spherical roller bearings require a steel quality beyond reproach. Two main considerations: strictly observed casting process and inclusion cleanliness. The SNR steel suppliers are selected worldwide, in line with these two criteria. The corporate agreements implemented with them guarantees reliable availability and perfect traceability.

While continuously improving measurement accuracy, SNR has maintained the same test principles for thirty-five years! These constant principles are valuable, having allowed us to assess and control the evolution of the steels for several decades.

Service life is almost doubled

Some 15 years ago, the best steelworks in the world used to reach a minimum performance criterion of 250 hours for 100 Cr6 steel in SNR's severe testing conditions. The cooperative work with our suppliers allowed us to achieve the new steel quality, raising the performance criteria to more than 450 hours: below this threshold, SNR refuses any steel production.

With both rings manufactured from this new quality steel, an a_2 coefficient equal to 1.75 could be integrated in the corrected service life calculation. This is the minimum guaranteed value. In fact, this rate is regularly exceeded: the average of the steel batches used would allow a factor 3 or 4 to be applied by adopting this minimum value.

SNR focuses on safety, for all types of applications.

I Test protocol

SNR systematically qualifies each supplier's performance, and each steel's quality, through test benches referred to as "FB2". In fact, we test the intrinsic performance of the material in bearing applications, totally irrespective of all parameters which could be attributed to bearing geometry.

The test consists of trying a large number of samples under high loads and at 1,500 rpm, and deducing the service life (L_{10}) reached by 90% of the samples.

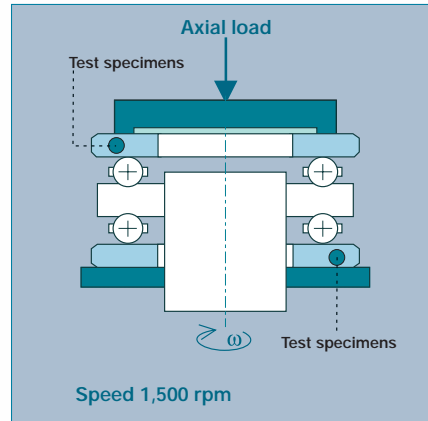

Heat treatment: protecting against wear

The specific spherical roller bearings heat treatment guarantees dimensional stability, even at very high temperature. It provides the bearing with its intended operating properties: resistance to failure and wear, reliability. The tempering treatment after quenching provides a martensitic structure, with suitable durability, allowing our bearings to withstand extreme operating conditions.

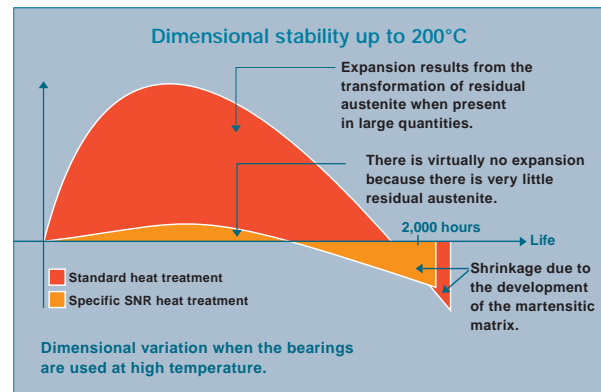

Cage surface treatment: optimized lubrication

In the SNR Premier bearings, the steel cages are protected from corrosion by a phosphate treatment which changes the superficial steel structure,

making it porous, so that it acts as an oil pump. This guarantees a lubricant film at cage contact with rollers and inner race, thereby limiting friction wear.



Design, geometry: 3D efficiency



Simple design, high performance, high reliability bearings

The SNR Premier spherical rollers are guided by a minimum number of components; rollers are only guided by the tabs in the cage pockets (*). This reduced number of components is a key factor, facilitating parameter control (thermal expansion, tolerances...). Also, shoulders have been eliminated, reducing friction; precision is improved, and load capacity optimized.

Maximum load capacity, robust rollers

In addition to the quality of the steel, a bearing's load capacity essentially depends on the number and size of the rolling elements.

The SNR Premier spherical roller bearings feature larger rollers, and in larger quantity. The redesigned races also ensure better load distribution.

(* when design permits.

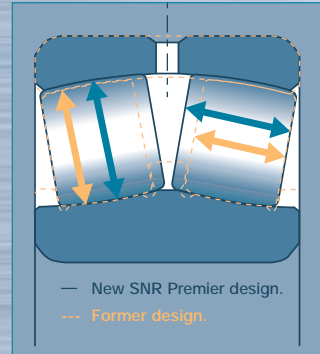

Larger diameter rollers, thanks to a corresponding reduction of the ring thickness, allowed by the improvements in the steel and the heat treatment and machining technologies.

Longer rollers, thanks to the removal of the shoulder sections whose guidance function was assumed by the bearing races and the geometry of the cage.

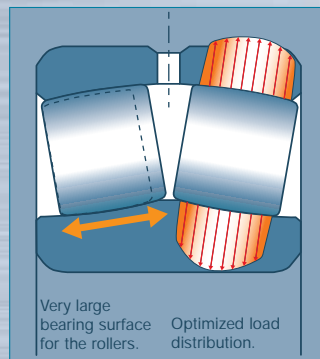

Optimized bearing races, ensuring:

- A larger bearing surface for the roller on the race, thanks to the elimination of lateral and central shoulders.
- Better load distribution, by optimized relative curvatures, in order to obtain a homogenous distribution of the loads along the roller width.
- Improved roller / race contact thanks to a better control of the shapes and surface conditions, resulting from the use of new inspection and machining methods.

Tests and calculations: state-of-the-art means for an ideal solution

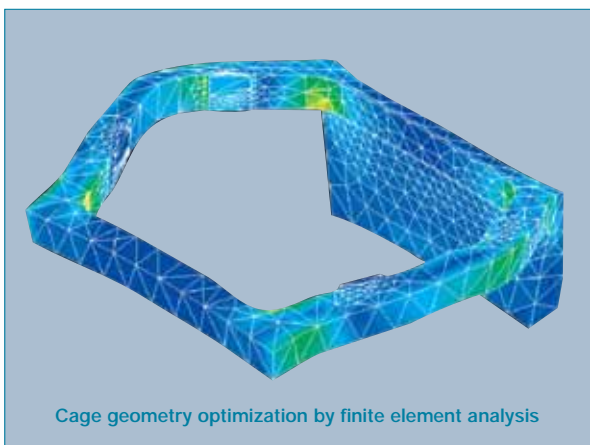

In a bearing, all parameters interact and must be considered at the same time: geometry, lubrication, friction, to obtain the best compromise. In this research work, SNR implements two types of tools: tests, and analysis software, benefiting from many years of experience.

In fact, suppressed shoulder sections, roller guidance by the race and cage were validated by thousands



of test hours on endurance benches and series-production qualification tests.

Our analysis programs simultaneously integrate all parameters: kinematics, lubricant viscosity, geometry, loads. They provide access to more than 1,000 possible solutions for a bearing of the same standard dimensional envelope (ISO), allowing us to propose optimum solutions according to the type of cage used.

Manufacturing facilities & methods to match the goals of the Premier range.

Our engineers are not only seeking the best product: they also look for the best methods in order to guarantee the bearing quality in large quantity production.

For example, SNR commits itself to ensure equivalent precision and tolerance homogeneity both on solid, steel sheet or cast cages.

The manufacturing and inspection process layouts were approved as accurate specifications. Combining quality and productivity, excluding any

quality drift in the course of time: these principles enabled SNR to attain the highest levels in the aerospace and automotive sectors. They are in effect in the Premier range.

Thanks to a production quality assurance system and a continuous improvement effort on machines and processes, the Premier bearing finishing level is achieving unrivalled regularity.





Cages: the bearing's back-bone

Cage failure results in bearing failure and consequently, machine failure. Failure prevention and adaptation to all applications are obtained by optimizing the various types of cages, available in diversified materials: polyamide, steel sheet, brass.



SNR PREMIER EG15 SERIES

Average temperature applications

Polyamide 6.6 nylon cage,
filled with 25 % glass fiber

This bearing is designed for all general applications when temperature does not exceed 150°C.

- **Very good strength** thanks to the material, providing flexibility and elasticity, as well as dual design: each row of rollers is guided by its own cage.
- **Very good roller guidance** thanks to its « window style » design, obtained from a specific cast process, guaranteeing high reliability.
- **Good lubrication**, improved by the cage design: apertures in the external shroud, low polyamide / steel friction coefficient. This cage ensures good distribution of the lubrication film.
- **Low noise level**, thanks to the material used.
- **Good corrosion resistance**: no alteration of the cage in case of accidental presence of water. Non-conductive and resistant to many chemical or electrochemical agents.

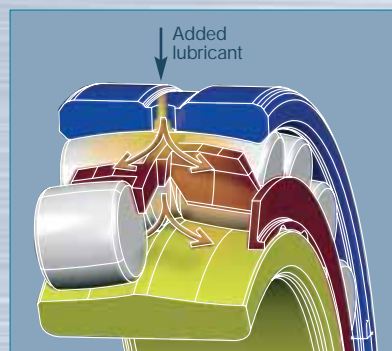
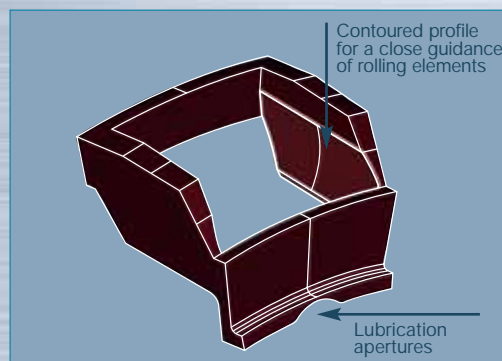
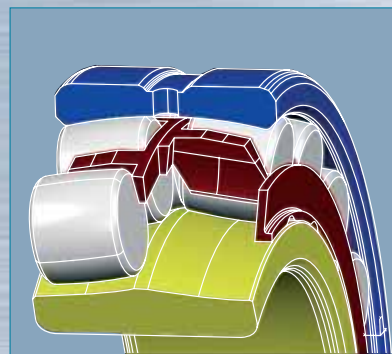



SNR PREMIER EA SERIES

General and extreme temperature applications

Steel sheet cage

This bearing is designed for all general applications and more particularly when the operating temperature exceeds 150°C.

- **Resistance to high and low temperatures:** from -60 to +200°C, thanks to the bearing ring dimensional stabilization heat treatment, complemented by a suitable lubricant.
- Accurate cage centering, on the ground surface of the inner ring's bearing race and on the large rolling elements, resulting in **more precise roller guidance**.
- Precise guidance of the rollers, retained by the pockets, each comprising 4 retaining tabs with a controlled chamfer, for perfect positioning of the rolling elements without added components. This guarantees minimized friction and overheating, for **an increased service life, with reduced maintenance**.
- The surface treatment (phosphatizing - oiling) reduces the friction coefficient and the wear, for **higher resistance at high speed**.
- **Excellent lubrication** due to the shape of the cage which increases the lubricant reserves in the bearing and facilitates its flow.

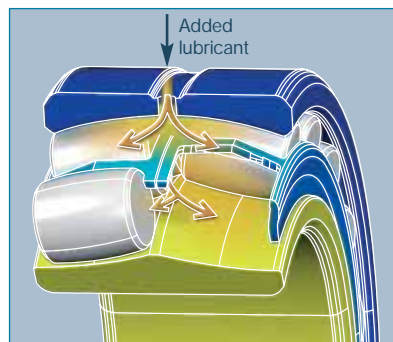
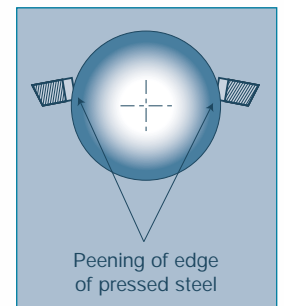
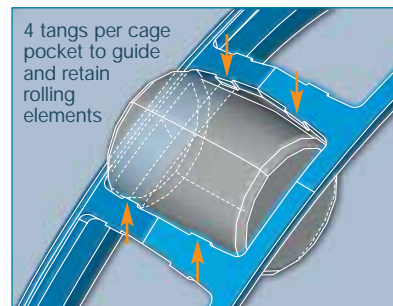
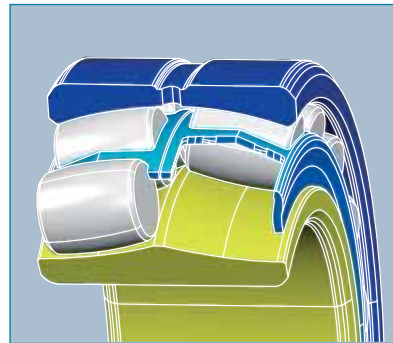

The series 24000 is a very wide series, with extra-long rollers ensuring optimized capacity. Therefore, SNR decided to maintain the lateral shoulders and the central rib.





Cages: the bearing's back-bone



SNR PREMIER EM SERIES

Demanding applications

Solid copper alloy cage (brass)

This bearing provides a solution for temperatures up to 200°C, with tough operating conditions (high speeds, shock loads, contamination).

- **Minimized resonance**, due to the one-piece cage.
- **Resistance to shocks and highest rigidity** due to the plastic deformation capacity of the material (copper alloy – brass)
- **Friction reduction**, due to:
 - the self-lubricating properties of the cage material, reducing friction at high speed.
 - The cage centered on the rolling elements, with lateral shoulder sections on the inner ring. The absence of a cage / ring contact prevents any component from siezing in case of thermal expansion.
- **Perfect roller radial guidance** and good roller / cage load **distribution**, by the pockets surrounding the rolling elements.

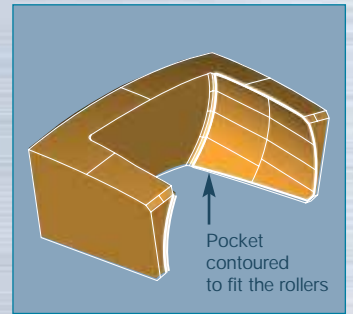

SNR PREMIER EF800 SERIES

High vibration applications

Solid copper alloy cage (brass), reduced internal tolerance & clearance ranges

The vibratory mechanisms such as those found in shaker screens, crushers, grinders or construction equipment engines, are the most demanding applications for spherical roller bearings.

- **Resistance to vibrations**, by the solid one-piece machined cage, which **minimizes resonance phenomena**, and their induced failures.
- **Strengthened roller retention under vibrations**, thanks to the lateral shoulders in the inner ring and to the internal clearance control at installation. To ensure correct operation in vibration applications, the tolerances on the outer diameter, the bore and the internal clearance are reduced.
- **Special radial play**: C4, utilizing the upper 2/3 of the tolerance range, in order to perfectly control the internal clearance after installation. This type of special tolerance is also available in classes C0 and C3.

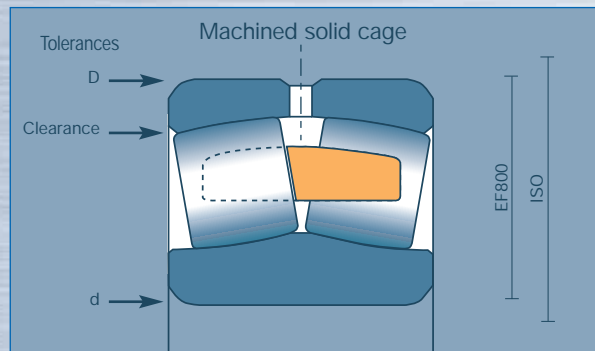

Cage selection guidelines

Selection criteria	Series			
	EA series	EM series	EF800 series	EG15 series
Applications	General	Difficult	Vibrating	General
Cage materials	Steel, Surface treatment	Copper alloys	Copper alloys	Polyamide 6.6 (reinforced with 25% glass fibers)
Operating temperatures	Up to 200°C (392°F)	Up to 200°C (392°F)	Up to 200°C (392°F)	Up to 120°C (250°F) continuous and 150°C (302°F) transient peak
Resistance to impacts and vibrations	***	*****	*****	*****
Resistance to friction	***	****	****	*****
Resistance to heating	*****	*****	*****	***

- *** : average
 **** : good
 ***** : excellent





Suitable lubrication: critical for long service

Lubrication is an essential element for correct operation of the bearing. In fact, 70% of premature failures are due to faulty lubrication. Viscosity is key, as well as lubricant distribution between the components, due to geometry and surface conditions. This point was particularly optimized in spherical roller bearings.

- **Suppressed shoulders** to offer a sufficient volume to correctly lubricate the bearing and ensure that the lubricant flow maintains a permanent grease film between rollers and races, thereby significantly reducing overheating.

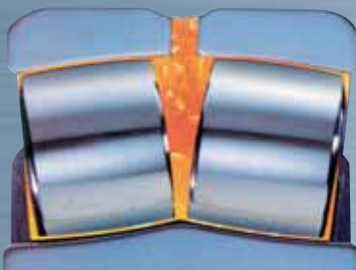

- **Lubrication grooves and holes:** enlarged lubrication grooves and increased diameter for the 3 lubrication holes located in the outer ring, to facilitate relubrication.

- **Cage design and material:**

- Steel sheet cage, with phosphate treatment to ensure lubricant retention.
- Solid brass cage, whose self-lubricating properties reduce high speed friction.
- Glass fiber - filled polyamide cage, with apertures in the outer shroud to facilitate lubrication. Lubrication is also improved by the polyamide-steel contact at the rollers, and by the material featuring high resistance to inadequate lubrication.

| Lubrication tips

It is critical to obtain satisfactory lubrication as early as the first rotation of the bearing. In case of lubrication by grease, ensure that the grease fully packs the available volume and, in particular the space between cage and inner ring.

For more information on lubrication tips and SNR products, refer to page 35.

SNR LubSolid: life lubrication

Spherical bearings with two rows of rollers, by their internal design expel grease from the rolling element / race contact points, are the types of bearings which consume the highest quantity of grease. Even sealed, they do not permit life lubrication. Therefore, for a speed factor $N.Dm = 100\ 000$, SNR proposes a new lubrication concept called LubSolid.

LubSolid is a porous polymer material containing a large quantity of oil. This matrix completely fills the free volume in the bearing providing 3 to 4 times more oil than with a conventional grease.

Spectacular performance in the following applications:

- **Bearings submitted to low amplitude oscillations** where the risk of false Brinelling is high. With SNR LubSolid, the performance rating can be multiplied by 20, versus the best available grease.
- **Bearings submitted to strong centrifugal effect** (4000g's). The grease is instantaneously expelled from the bearing, whereas the LubSolid material allows thousands of operating hours.

The bearings with LubSolid also meet the particular requirements of vacuum applications, in which the lubricant is even more severely altered (oil evaporation), and of agri-food where health hazards are high.

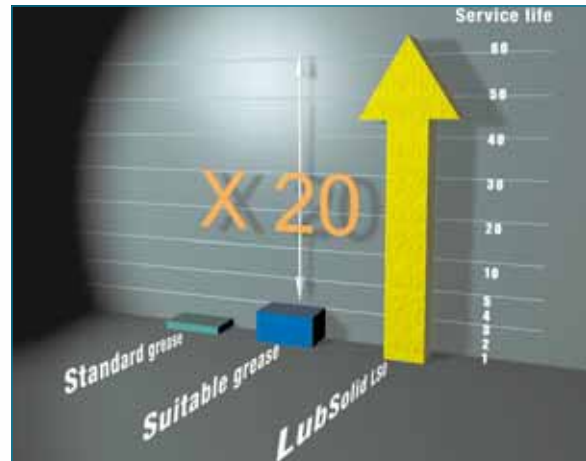

LubSolid's advantages:

- **Extended service life.** The core of the bearing is permanently supplied with oil.
- **No relubrication** required.
- **Environmentally friendly.**
- **Better sealing:** protection in case of dust aggression (this can be improved by adding grease in the bearing body).

SNR remains at your disposal to study the use of this concept in your applications.

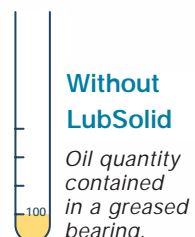
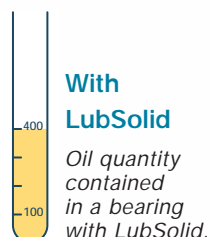



Speed: better knowledge to select the most appropriate bearing

Thermal reference speed n_{0r} (ISO 15312 standard)

The thermal reference speed is the inner ring rotating speed for which thermal equilibrium is reached, between heat produced by friction in the bearing and thermal flow emitted through the bearing seat (shaft and bearing housing), in reference conditions.

Reference conditions determining heat generation by friction:

- Bearing reference temperature on fixed outer ring θ_r : 70°C.
- Bearing reference ambient temperature θ_{Ar} : 20°C.
- Reference load $P_{1r} = 0,05 \times C_{0r}$ (5% of the basic static load, taken as pure radial load).
- Lubricant: mineral oil without extreme pressure additives, featuring, at $\theta_r = 70^\circ\text{C}$, a kinematic viscosity $\nu_r = 12 \text{ mm}^2/\text{s}$ (ISO VG 32).

- Lubrication method: oil bath, with oil level up to, the center of the rolling element at its lowest position.
- Bearing size range: up to and including a bore diameter of 1,000 mm.
- Internal clearance: group « N ».
- Bearing rotation axis: horizontal.
- Fixed outer ring.

The reference conditions for grease lubrication are determined so that the thermal reference speed is identical to oil bath lubrication reference speed.

Limit speed

The admissible limit speed depends on mechanical limitations such as the ultimate failure strength of the bearing components.

If you wish to exceed the admissible limit speed indicated in the table (page 23-27), consult your SNR contact.

Admissible operating thermal speed

The admissible operating speed n_{adm} is the rotating speed at which the mean bearing temperature reaches the admissible limit value, in actual operating conditions.

To obtain an approximate calculation of the operating thermal speed, multiply the reference speed n_{or} by the coefficients f_p and f_v that originate from the table opposite.

$$n_{adm} = n_{or} \times f_p \times f_v$$

To perform a more accurate analysis based on standards, use the formulae listed below.

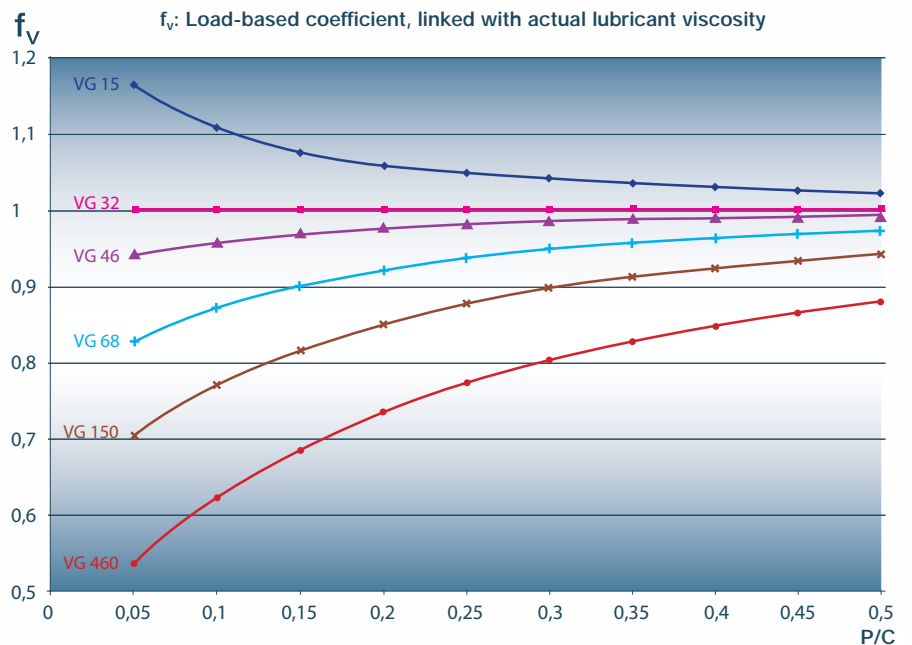
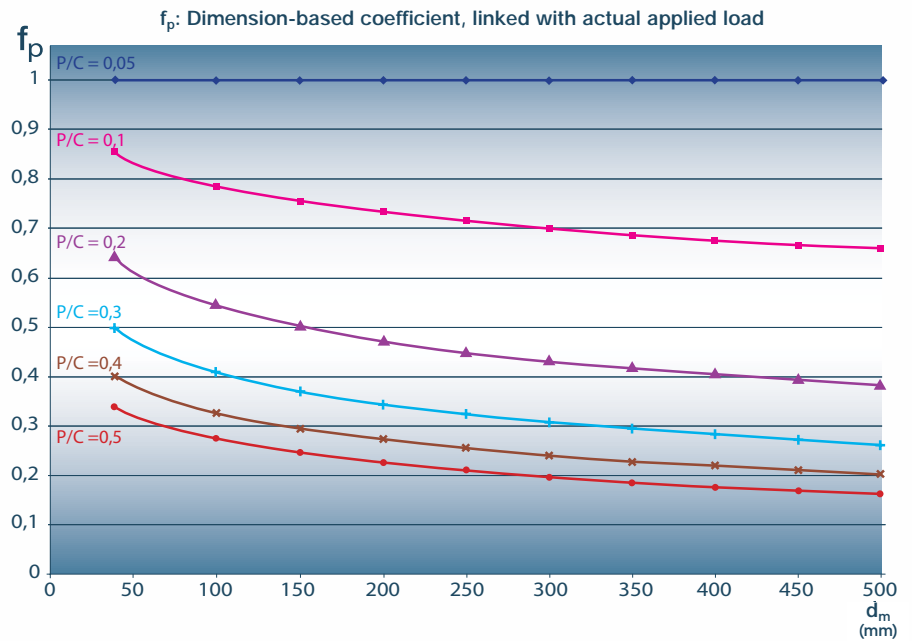

Mathematic calculation based on Standards

The standard permits a calculation based on all parameters which can be indicated, in lieu of the reference values.

In particular, the following parameters can be taken into account:

- actual load P ,
- deviation between ambient temperature and internal bearing temperature $\Delta\theta$,
- actual viscosity ν .

The equation to determine n_{adm} is:

$$\frac{\pi \times n_{adm}}{30} \times [10^{-7} f_{or} \times (\nu \times n_{adm})^{2/3} \times d_m^3 + f_{1r} \times P \times d_m] = 10^3 \times q_r \times A_r$$

d_m = mean diameter $(D+d)/2$

A_r = bearing journal area $A_r = \pi (D+d)B$

$q_r = 0.016 (\Delta\theta/50) (A_r/50000)^{-0.34}$ w/mm² if $A_r > 50000$ mm²

f_{1r} : friction coefficient linked to load, drawn from ISO 15312 standard, Appendix A (values for information)

f_{or} : friction coefficient linked with speed, drawn from ISO 15312 standard, Appendix A (values for information)

An iterative process is necessary to solve this equation.

Starting from a zero or low initial value for n_{adm} the n_{adm} value is incremented until equality is obtained.





Technical information: fundamentals

Standards

The SNR Premier spherical roller bearings meet the requirements in the DIN 635-2 and ISO 15 standards.

Misalignment

The SNR Premier spherical roller bearings admit misalignment to the order of 0.5°, without reduction in service life. However, this angle must be limited in

order to remain within values in keeping with the sealing system used.

Tolerances

The SNR Premier spherical roller bearings are delivered in standard precision class: ISO 492 standard. Upon request, SNR can deliver bearings with reduced tolerances, on one or more characteristics (bore, outer diameter, rotation precision, inner ring,...).

The EF800 range features tight tolerances on the outer diameter and the bore, as well as the reduced internal clearance tolerance. They provide better control of the residual play after installation, which must remain as low as possible.

Inner ring – Reduced bore tolerances

Dimensions in mm		30	50	80	120	180
Nominal bore	greater than	30	50	80	120	180
	up to	50	80	120	180	250
Micron-scale differences						
Cylindrical bore	d_m, d	0	0	0	0	0
		-7	-9	-12	-15	-18
Tapered bore	d	25	30	35	40	46
		0	0	0	0	0
Width	B	0	0	0	0	0
		-120	-150	-200	-250	-300

Outer ring – Reduced tolerances on the outside diameter

Dimensions in mm		80	120	150	180	250	315	400	500
Nominal outside Diameter	greater than	80	120	150	180	250	315	400	500
	up to	120	150	180	250	315	400	500	630
Micron-scale differences									
Outside diameter	D_m, D	-5	-5	-5	-10	-10	-13	-13	-15
		-13	-13	-18	-23	-23	-28	-30	-35

The outer ring has the same width tolerance as the inner ring.

Internal clearance

Radial play

Radial play is defined by the ISO 5753 standard. The values are different for tapered bore bearings due to the strongly reduced internal clearance from interference fitting during installation.

Residual play order of magnitude J_{rm} recommended:
 $J_{rm} = 5 \cdot \sqrt{\alpha} \cdot 10^{-3}$

To meet the requirements of various installations and operating conditions, SNR proposes a basic design of bearings with normal clearance and, upon request, bearings with increased radial play C3, C4, etc.

EF800 range: standard choice to meet usual applications: C4 for standard design EF800, C3 for EF801 design and C0 for EF802 design. These tolerances are reduced to the upper 2/3 of the clearance range considered, in order to ensure proper clearance control after installation.

Reduced radial clearance tolerances														
Dimensions in mm														
Nominal bore	greater than 30	40	50	65	80	100	120	140	160	180	200	225	250	
	up to	40	50	65	80	100	120	140	160	180	200	225	250	
With cylindrical bore														
Clearances in microns														
Group of clearances	min.	65	85	100	120	150	180	205	240	260	285	320	355	385
EF800 (C4)	max.	80	100	120	145	180	210	240	280	310	340	380	420	460
Clearances in microns														
Group of clearances	min.	50	60	75	90	110	135	160	190	200	220	245	265	290
EF801 (C3)	max.	60	75	90	110	135	160	190	220	240	260	290	320	350
Clearances in microns														
Group of clearances	min.	35	40	50	60	75	90	110	130	140	155	165	180	200
EF802 (C0)	max.	45	55	65	80	100	120	145	170	180	200	220	240	260
With tapered bore (taper 1/12)														
Clearances in microns														
Group of clearances	min.	70	85	105	130	155	185	220	255	285	315	350	385	425
EKF800 (C4)	max.	85	100	120	150	180	220	260	300	340	370	410	450	490
Clearances in microns														
Group of clearances	min.	55	65	80	100	120	145	175	195	220	245	275	295	330
EKF801 (C3)	max.	65	80	95	120	140	170	200	230	260	290	320	350	390
Clearances in microns														
Group of clearances	min.	40	50	60	80	90	110	135	145	160	180	205	225	245
EKF802 (C0)	max.	50	60	75	95	110	135	160	180	200	220	250	270	300

Axial play

Axial play, J_a depends upon radial play, J_r , therefore, it can be estimated using the following formula:

$$J_a = 2,27 Y_0 \cdot J_r$$





Technical information: fundamentals

Internal clearance reduction at installation

The bearing residual play must be controlled after installation. This precaution is mandatory for tapered bore bearings.

The relationship between axial displacement (a) in a tapered bore bearing and the corresponding reduction of its radial play ΔJ_r is as follows:

Taper 1/12: $a = 12 \Delta J_r / t_i$

Taper 1/30: $a = 30 \Delta J_r / t_i$

*For more details,
refer to the installation section, page 29.*

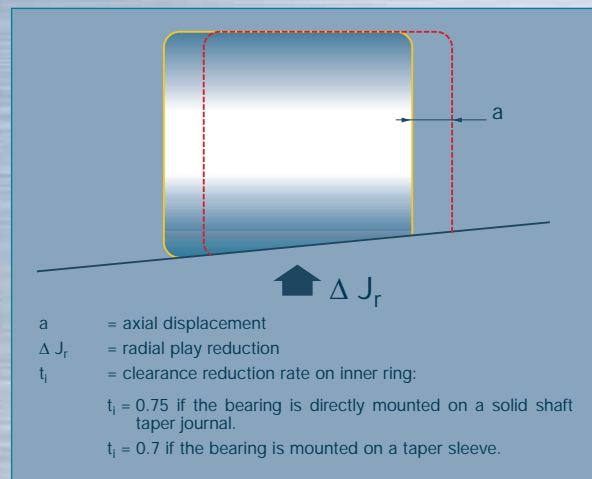

Installation & Adjustment

Periodic installation and removal causes modifications to the geometrical tolerances and to the shapes of the bearing housings and shafts. When fitting a new bearing, the geometry must be carefully checked; particularly at bearing housing and W33 lubrication groove level where bearing housing defects often occur in the groove, forming ridges on the edge.

In this case, be careful before re-installing the bearings in these worn housings.

EF800 series (for vibrating or rotating load applications): the following fits & adjustments are recommended for new bearing housings:

- Tight fit at bearing housing: class P6.
- Slip fit at shaft level: class g6.

Cylindrical and tapered bores

The large majority of SNR Premier spherical roller bearings are available both in cylindrical and tapered bore (taper 1/12), identified by the suffix K. The 24000 and 24100 series bearings feature 1/30 taper, with K30 suffix.

Lubrication groove and holes

The SNR Premier spherical roller bearings are delivered protected with an anti-oxidant and not lubricated.

To facilitate lubrication, all SNR spherical roller bearings, except those of the 21300 series, are equipped with a lubrication groove, and 3 lubrication holes on the outer ring, identified by suffix W33. Their dimensions are indicated on pages 23 to 27.

Upon request, these bearings can be delivered without lubrication groove or holes.

For vertical shaft applications, particular attention must be paid to the lubricant supply. SNR recommends oil lubrication.

Fitting dimensions

The values mentioned in the tables on pages 23 to 27 concern the maximum value of r_1 and the shoulder section diameter.

For adapter sleeve mounting, the bearing ring dimensions must be taken into account.





Designations and suffixes

SNR takes advantage of the Premier range launch to change our references to become more uniform with the market designations. For practical reasons, this evolution will allow you to save time when placing orders and avoid any risk of confusion.

Former designation	New designation
E	EG15
EA	EA
EB33M	EMW33
VB33M	VMW33
B33	W33
Jx0	Cx
V*	EA*

*For 24000 and 24100 series

Former designation (example)

2 2 3 1 4 E K B 3 3 M J 3 0

Cages

- A** high capacity bearing, steel sheet cage
- M** high capacity bearing, solid copper alloy cage (brass)
- G15** polyamide 6.6 cage (with 25% fiber glass fill)

New designation

2 2 3 1 4 E M K W 3 3 C 3

Internal characteristics

- V** internal design index
- E** internal design index, reinforced manufacturing

Bore types

- K** tapered bore, 1/12
- K30** tapered bore, 1/30

Technical characteristics

- N** snap-ring groove in outer ring
- W33** lubrication groove and holes in outer ring
- F800** bearing with solid cage for vibration applications, clearance upper 2/3 of C4
- F801** bearing with solid cage for vibration applications, clearance upper 2/3 of C3
- F802** bearing with solid cage for vibration applications, clearance upper 2/3 of C0

Internal clearances

- C** The figure refers to the ISO clearance category
- C2** clearance < normal
- C0** clearance normal (reference not included in part number)
- C3** clearance > normal
- C4** clearance > C3



Range

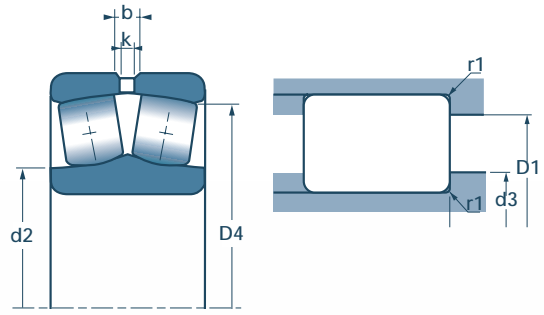

OVERALL DIMENSIONS					BASIC CAPACITIES x 1,000 newton		SPEEDS		WEIGHTS (kg)	DESIGNATIONS	FITTING DIMENSIONS				
mm					Dynamic	Static	rpm		Bore	Bore	mm				
d	D	B	b	k	C	C ₀	limit	reference	cylindrical	cylindrical	d ₂ ≈	d ₃ min	D ₁ max	D ₄ ≈	r ₁ max
25	52	18	3	1,5	54,4	46,1	17 000	11 000	0,17	• 22205.EAW33	30	30	46	46	1
	52	18	3	1,5	54,4	46,1	17 000	11 000	0,16	• 22205.EG15W33	30	30	46	46	1
	52	18	3	1,5	54,4	46,1	17 000	11 000	0,17	• 22205.EMW33	30	30	46	46	1
	62	17			48,5	37,5	12 000	9 100	0,25	21305.V	34	32	55	52	1,1
30	62	20	4,4	2	72	64,5	13 800	9 300	0,27	• 22206.EAW33	37	36	56	55	1
	62	20	4,4	2	72	64,5	13 800	9 300	0,26	• 22206.EG15W33	37	36	56	55	1
	62	20	4,4	2	68,4	60,2	13 800	9 300	0,28	• 22206.EMW33	37	36	56	55	1
	72	19			63	50	10 000	7 700	0,38	21306.V	40	37	65	60	1,1
35	72	23	4,9	2	95,4	92	11 000	8 300	0,43	• 22207.EAW33	45	42	65	63	1,1
	72	23	4,9	2	95,4	92	11 000	8 300	0,42	• 22207.EG15W33	45	42	65	63	1,1
	72	23	4,9	2	95,4	92	11 000	8 300	0,44	• 22207.EMW33	45	42	65	63	1,1
	80	21			79	66	9 500	6 900	0,50	21307.V	46	44	71	68	1,5
40	80	23	5,4	2,5	110	105	10 800	7 300	0,52	• 22208.EAW33	50	47	73	71	1,1
	80	23	5,4	2,5	110	105	10 800	7 300	0,49	• 22208.EG15W33	50	47	73	71	1,1
	80	23	5,4	2,5	105	98	10 800	7 300	0,52	• 22208.EMW33	50	47	73	71	1,1
	90	23			96	84	9 000	6 100	0,70	21308.V	53	49	81	76	1,5
	90	33	5,9	3	161	152	7 300	5 300	1,00	• 22308.EAW33	52	49	81	78	1,5
	90	33	5,9	3	161	152	7 300	5 300	1,02	• 22308.EF800	52	49	81	78	1,5
	90	33	5,9	3	161	152	7 300	5 300	0,96	• 22308.EG15W33	52	49	81	78	1,5
	90	33	5,9	3	161	152	7 300	5 300	1,03	• 22308.EMW33	52	49	81	78	1,5
45	85	23	5,8	2,5	115	113	10 000	6 600	0,57	• 22209.EAW33	54	52	78	76	1,1
	85	23	5,8	2,5	115	113	10 000	6 600	0,54	• 22209.EG15W33	54	52	78	76	1,1
	85	23	5,8	2,5	110	106	10 000	6 600	0,57	• 22209.EMW33	54	52	78	76	1,1
	100	25			119	106	8 000	5 400	0,95	21309.V	59	54	91	85	1,5
	100	36	6,4	3	196	187	6 800	4 800	1,35	• 22309.EAW33	58	54	91	87	1,5
	100	36	6,4	3	196	187	6 800	4 800	1,37	• 22309.EF800	58	54	91	87	1,5
	100	36	6,4	3	196	187	6 800	4 800	1,29	• 22309.EG15W33	58	54	91	87	1,5
	100	36	6,4	3	196	187	6 800	4 800	1,37	• 22309.EMW33	58	54	91	87	1,5
50	90	23	5,8	2,5	124	124	9 500	6 200	0,60	• 22210.EAW33	59	57	83	81	1,1
	90	23	5,8	2,5	124	124	9 500	6 200	0,58	• 22210.EG15W33	59	57	83	81	1,1
	90	23	5,8	2,5	118	117	9 500	6 200	0,61	• 22210.EMW33	59	57	83	81	1,1
	110	27			137	128	7 000	4 900	1,24	21310.V	66	61	99	93	2
	110	40	7,4	3,5	237	232	6 000	4 400	1,81	• 22310.EAW33	63	61	99	95	2
	110	40	7,4	3,5	237	232	6 000	4 400	1,83	• 22310.EF800	63	61	99	95	2
	110	40	7,4	3,5	237	232	6 000	4 400	1,73	• 22310.EG15W33	63	61	99	95	2
	110	40	7,4	3,5	237	232	6 000	4 400	1,83	• 22310.EMW33	63	61	99	95	2
55	100	25	6,3	3	147	148	8 500	5 500	0,82	• 22211.EAW33	66	64	91	90	1,5
	100	25	6,3	3	147	148	8 500	5 500	0,78	• 22211.EG15W33	66	64	91	90	1,5
	100	25	6,3	3	147	148	8 500	5 500	0,81	• 22211.EMW33	66	64	91	90	1,5
	120	29			167	158	6 500	4 500	1,54	21311.V	73	66	109	102	2
	120	43	7,8	3,5	282	274	5 500	4 000	2,29	• 22311.EAW33	68	66	109	104	2
	120	43	7,8	3,5	282	274	5 500	4 000	2,34	• 22311.EF800	68	66	109	104	2
	120	43	7,8	3,5	282	274	5 500	4 000	2,20	• 22311.EG15W33	68	66	109	104	2
	120	43	7,8	3,5	282	274	5 500	4 000	2,34	• 22311.EMW33	68	66	109	104	2
60	110	28	6,9	3	178	181	7 400	5 100	1,13	• 22212.EAW33	71	69	101	99	1,5
	110	28	6,9	3	178	181	7 400	5 100	1,07	• 22212.EG15W33	71	69	101	99	1,5
	110	28	6,9	3	170	171	7 400	5 100	1,15	• 22212.EMW33	71	69	101	99	1,5
	130	31			186	179	6 000	4 100	1,94	21312.V	79	72	118	110	2,1
	130	46	8,7	4	323	319	5 200	3 700	2,80	• 22312.EAW33	75	72	118	113	2,1
	130	46	8,7	4	323	319	5 200	3 700	2,89	• 22312.EF800	75	72	118	113	2,1
	130	46	8,7	4	323	319	5 200	3 700	2,71	• 22312.EG15W33	75	72	118	113	2,1
	130	46	8,7	4	323	319	5 200	3 700	2,89	• 22312.EMW33	75	72	118	113	2,1

Bearings available with cylindrical or tapered bore (EAK, EMK, EG15K). All clearance variants are available upon request. These bearings can be fitted by means of adapter or withdrawal sleeves (refer to selection guidelines, pages 31-33).





OVERALL DIMENSIONS					BASIC CAPACITIES x 1,000 newton		SPEEDS		WEIGHTS (kg)	DESIGNATIONS	FITTING DIMENSIONS				
mm					Dynamic	Static	rpm		Bore	Bore	mm				
d	D	B	b	k	C	C ₀	limit	reference	cylindrical	cylindrical	d ₂ [≠]	d ₃ min	D ₁ max	D ₄ [≠]	r ₁ max
65	120	31	7,8	3,5	215	224	6 500	4 700	1,51	• 22213.EAW33	78	74	111	107	1,5
	120	31	7,8	3,5	215	224	6 500	4 700	1,44	• 22213.EG15W33	78	74	111	107	1,5
	120	31	7,8	3,5	206	212	6 500	4 700	1,59	• 22213.EMW33	78	74	111	107	1,5
	140	33			224	215	5 500	3 800	2,38	21313.V	85	77	128	120	2,1
	140	48	9,2	4	351	343	4 800	3 400	3,41	• 22313.EAW33	81	77	128	122	2,1
	140	48	9,2	4	351	343	4 800	3 400	3,49	• 22313.EF800	81	77	128	122	2,1
	140	48	9,2	4	351	343	4 800	3 400	3,27	• 22313.EG15W33	81	77	128	122	2,1
	140	48	9,2	4	351	343	4 800	3 400	3,49	• 22313.EMW33	81	77	128	122	2,1
70	125	31	7,4	3,5	224	240	6 300	4 400	1,59	• 22214.EAW33	84	79	116	113	1,5
	125	31	7,4	3,5	224	240	6 300	4 400	1,52	• 22214.EG15W33	84	79	116	113	1,5
	125	31	7,4	3,5	224	240	6 300	4 400	1,68	• 22214.EMW33	84	79	116	113	1,5
	150	35			246	240	5 000	3 600	2,92	21314.V	91	82	138	127	2,1
	150	51	10,4	5	400	396	4 500	3 200	4,18	• 22314.EAW33	85	82	138	131	2,1
	150	51	10,4	5	400	396	4 500	3 200	4,27	• 22314.EF800	85	82	138	131	2,1
	150	51	10,4	5	400	396	4 500	3 200	3,99	• 22314.EG15W33	85	82	138	131	2,1
	150	51	10,4	5	400	396	4 500	3 200	4,27	• 22314.EMW33	85	82	138	131	2,1
75	130	31	7,4	3,5	232	249	6 000	4 200	1,64	• 22215.EAW33	88	84	121	118	1,5
	130	31	7,4	3,5	232	249	6 000	4 200	1,58	• 22215.EG15W33	88	84	121	118	1,5
	130	31	7,4	3,5	232	249	6 000	4 200	1,71	• 22215.EMW33	88	84	121	118	1,5
	160	37			280	275	4 900	3 400	3,49	21315.V	97	87	148	137	2,1
	160	55	10,3	5	467	467	4 300	3 000	5,08	• 22315.EAW33	91	87	148	139	2,1
	160	55	10,3	5	467	467	4 300	3 000	5,21	• 22315.EF800	91	87	148	139	2,1
	160	55	10,3	5	467	467	4 300	3 000	4,91	• 22315.EG15W33	91	87	148	139	2,1
	160	55	10,3	5	467	467	4 300	3 000	5,21	• 22315.EMW33	91	87	148	139	2,1
80	140	33	7,9	3,5	265	287	5 500	3 900	2,07	• 22216.EAW33	94	91	129	127	2
	140	33	7,9	3,5	265	287	5 500	3 900	1,99	• 22216.EG15W33	94	91	129	127	2
	140	33	7,9	3,5	254	272	5 500	3 900	2,16	• 22216.EMW33	94	91	129	127	2
	170	39			305	305	4 800	3 200	4,13	21316.V	104	92	158	145	2,1
	170	58	10,4	5	515	522	4 000	2 800	6,03	• 22316.EAW33	98	92	158	148	2,1
	170	58	10,4	5	515	522	4 000	2 800	6,20	• 22316.EF800	98	92	158	148	2,1
	170	58	10,4	5	515	522	4 000	2 800	5,81	• 22316.EG15W33	98	92	158	148	2,1
	170	58	10,4	5	515	522	4 000	2 800	6,26	• 22316.EMW33	98	92	158	148	2,1
85	150	36	7,9	3,5	308	330	5 200	3 600	2,56	• 22217.EAW33	100	96	139	137	2
	150	36	7,9	3,5	308	330	5 200	3 600	2,45	• 22217.EG15W33	100	96	139	137	2
	150	36	7,9	3,5	308	330	5 200	3 600	2,64	• 22217.EMW33	100	96	139	137	2
	180	41			355	365	4 700	3 000	5,23	21317.VM	111	99	166	154	3
	180	60	11	5	570	604	3 700	2 600	7,06	• 22317.EAW33	107	99	166	157	3
	180	60	11	5	570	604	3 700	2 600	7,23	• 22317.EF800	107	99	166	157	3
	180	60	11	5	570	604	3 700	2 600	7,23	• 22317.EMW33	107	99	166	157	3
	90	160	40	10,2	4,5	366	398	5 000	3 500	3,28	• 22218.EAW33	105	101	149	144
160		40	10,2	4,5	366	398	5 000	3 500	3,16	• 22218.EG15W33	105	101	149	144	2
160		40	10,2	4,5	366	398	5 000	3 500	3,42	• 22218.EMW33	105	101	149	144	2
160		52,4	8,86	4	445	513	4 300	2 900	4,38	• 23218.EAW33	104	101	149	141	2
160		52,4	8,86	4	445	513	4 300	2 900	4,41	• 23218.EMW33	104	101	149	141	2
190		43			385	400	4 500	3 000	6,11	21318.VM	117	104	176	162	3
190		64	11,56	5	636	652	3 600	2 500	8,29	• 22318.EAW33	110	104	176	166	3
190		64	11,56	5	636	652	3 600	2 500	8,50	• 22318.EF800	110	104	176	166	3
95	170	43	9,93	4,5	395	417	4 600	3 200	3,93	• 22219.EAW33	110	107	158	153	2,1
	170	43	9,93	4,5	395	417	4 600	3 200	4,14	• 22219.EMW33	110	107	158	153	2,1
	200	67	12,15	6	696	751	3 200	2 300	9,75	• 22319.EAW33	120	109	186	174	3
	200	67	12,15	6	696	751	3 200	2 300	9,97	• 22319.EF800	120	109	186	174	3
	200	67	12,15	6	696	751	3 200	2 300	9,97	• 22319.EMW33	120	109	186	174	3

Bearings available with cylindrical or tapered bore (EAK, EMK, EG15K). All clearance variants are available upon request. These bearings can be fitted by means of adapter or withdrawal sleeves (refer to selection guidelines, pages 31-33).

• Premier

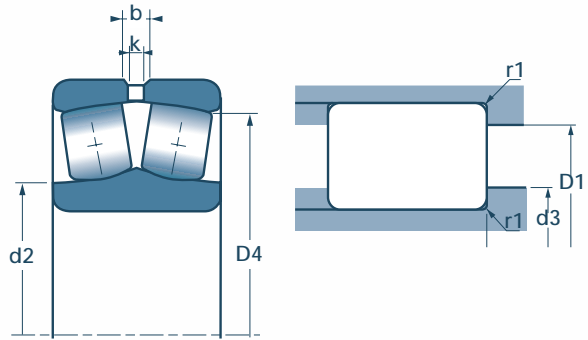

OVERALL DIMENSIONS	BASIC CAPACITIES x 1,000 newton					SPEEDS		WEIGHTS (kg)	DESIGNATIONS	FITTING DIMENSIONS						
	mm					Dynamic	Static	rpm	Bore	Bore	mm					
	d	D	B	b	k	C	C ₀	limit	reference	cylindrical	cylindrical	d ₂ [≅]	d ₃ min	D ₁ max	D ₂ [≅]	r ₁ max
100	150	50	6,4	3,5	325	425	3 800	2 500	2,83	• 24020.EAW33	108	107	143	136	1,5	
	165	52	8,4	4	448	575	4 200	2 800	4,32	• 23120.EAW33	114	111	154	147	2	
	165	52	8,4	4	448	575	4 200	2 800	4,26	• 23120.EG15W33	114	111	154	147	2	
	165	52	8,4	4	448	575	4 200	2 800	4,37	• 23120.EMW33	114	111	154	147	2	
	180	46	11,2	5	449	495	4 200	3 100	4,82	• 22220.EAW33	118	112	168	161	2,1	
	180	46	11,2	5	449	495	4 200	3 100	4,60	• 22220.EG15W33	118	112	168	161	2,1	
	180	46	11,2	5	449	495	4 200	3 100	5,08	• 22220.EMW33	118	112	168	161	2,1	
	180	60,3	9,44	4,5	558	661	3 500	2 300	6,38	• 23220.EAW33	118	112	168	159	2,1	
	180	60,3	9,44	4,5	558	661	3 500	2 300	6,48	• 23220.EMW33	118	112	168	159	2,1	
	215	73	13,3	6	787	844	3 000	2 200	12,41	• 22320.EAW33	127	114	201	187	3	
	215	73	13,3	6	787	844	3 000	2 200	12,78	• 22320.EF800	127	114	201	187	3	
	215	73	13,3	6	787	844	3 000	2 200	12,78	• 22320.EMW33	127	114	201	187	3	
	110	170	45	7,83	3,5	397	517	4 300	3 000	3,59	• 23022.EAW33	123	119	161	155	2
		170	45	7,83	3,5	397	517	4 300	3 000	3,61	• 23022.EMW33	123	119	161	155	2
180		56	8,86	4	521	669	4 000	2 700	5,45	• 23122.EAW33	125	121	169	161	2	
180		56	8,86	4	521	669	4 000	2 700	5,48	• 23122.EMW33	125	121	169	161	2	
180		69	8,4	4	530	675	2 600	1 300	6,48	• 24122.EAW33	121	121	169	158	2	
200		53	12,2	6	573	643	4 000	2 800	6,93	• 22222.EAW33	130	122	188	179	2,1	
200		53	12,2	6	573	643	4 000	2 800	6,72	• 22222.EG15W33	130	122	188	179	2,1	
200		53	12,2	6	573	643	4 000	2 800	7,22	• 22222.EMW33	130	122	188	179	2,1	
200		69,8	10,52	5	716	869	3 200	2 300	9,25	• 23222.EAW33	130	122	188	176	2,1	
200		69,8	10,52	5	716	869	3 200	2 300	9,33	• 23222.EMW33	130	122	188	176	2,1	
240		80	15,6	7	928	972	2 800	2 000	16,76	• 22322.EAW33	139	124	226	209	3	
240		80	15,6	7	928	972	2 800	2 000	17,41	• 22322.EF800	139	124	226	209	3	
240		80	15,6	7	928	972	2 800	2 000	17,41	• 22322.EMW33	139	124	226	209	3	
120		180	46	7,83	3,5	424	577	4 200	2 900	3,96	• 23024.EAW33	134	129	171	165	2
		180	46	7,83	3,5	424	577	4 200	2 900	3,99	• 23024.EMW33	134	129	171	165	2
		180	60	7,34	3,5	465	640	3 000	2 100	5,01	• 24024.EAW33	131	129	171	165	2
	180	60	7,34	3,5	465	640	3 000	2 100	5,06	• 24024.VMW33	131	129	171	162	2	
	200	62	10,04	4,5	630	820	3 400	2 400	7,62	• 23124.EAW33	138	131	189	179	2	
	200	62	10,04	4,5	630	820	3 400	2 400	7,70	• 23124.EMW33	138	131	189	179	2	
	200	80	10,05	4,5	695	925	2 200	1 200	9,73	• 24124.EAW33	133	131	189	172	2	
	215	58	12,16	6	654	753	3 600	2 500	8,69	• 22224.EAW33	141	132	203	193	2,1	
	215	58	12,16	6	654	753	3 600	2 500	8,94	• 22224.EMW33	141	132	203	193	2,1	
	215	76	11,01	5	815	998	2 800	1 900	11,62	• 23224.EMW33	139	132	203	190	2,1	
	260	86	18	8	1110	1280	2 500	1 800	22,35	• 22324.EAW33	156	134	246	225	3	
	260	86	18	8	1110	1280	2 500	1 800	22,60	• 22324.EF800	156	134	246	225	3	
	260	86	18	8	1110	1280	2 500	1 800	22,60	• 22324.EMW33	156	134	246	225	3	
	130	200	52	8,91	4	538	721	3 600	2 600	5,79	• 23026.EAW33	145	139	191	183	2
		200	52	8,91	4	538	721	3 600	2 600	5,94	• 23026.EMW33	145	139	191	183	2
		200	69	8,4	4	590	795	2 600	1 900	7,33	• 24026.EAW33	141	139	191	179	2
210		64	10,04	4,5	675	906	3 000	2 300	8,33	• 23126.EAW33	148	141	199	189	2	
210		64	10,04	4,5	675	906	3 000	2 300	8,43	• 23126.EMW33	148	141	199	189	2	
210		80	9,48	4,5	720	965	2 100	1 200	10,13	• 24126.EAW33	144	141	199	184	2	
230		64	13,21	6	768	898	3 500	2 400	10,77	• 22226.EAW33	151	144	216	206	3	
230		64	13,21	6	768	898	3 500	2 400	10,97	• 22226.EMW33	151	144	216	206	3	
230		80	11,56	5	912	1130	2 600	1 800	13,70	• 23226.EMW33	150	144	216	204	3	
280		93	18,9	9	1260	1400	2 400	1 700	26,80	• 22326.EAW33	164	144	263	243	4	
280		93	18,9	9	1260	1400	2 400	1 700	27,87	• 22326.EF800	164	147	263	243	4	
280		93	18,9	9	1260	1400	2 400	1 700	27,87	• 22326.EMW33	164	147	263	243	4	
140		210	53	8,91	4	568	783	3 500	2 500	6,21	• 23028.EAW33	155	149	201	193	2
		210	53	8,91	4	568	783	3 500	2 500	6,27	• 23028.EMW33	155	149	201	193	2
	210	69	9,9	4,5	625	900	2 500	1 800	7,66	• 24028.EAW33	153	149	201	189	2	
	225	68	10,54	5	763	1030	2 800	2 100	10,08	• 23128.EAW33	159	152	213	203	2,1	

Bearings available with cylindrical or tapered bore (EAK, EMK, EG15K). All clearance variants are available upon request. These bearings can be fitted by means of adapter or withdrawal sleeves (refer to selection guidelines, pages 31-33).

• Premier





OVERALL DIMENSIONS					BASIC CAPACITIES x 1,000 newton		SPEEDS		WEIGHTS (kg)	DESIGNATIONS	FITTING DIMENSIONS					
mm					Dynamic	Static	rpm		Bore	Bore	mm					
d	D	B	b	k	C	C ₀	limit	reference	cylindrical	cylindrical	d ₂ [≠]	d ₃ min	D ₁ max	D ₄ [≠]	r ₁ max	
140	225	68	10,54	5	763	1030	2 800	2 100	10,17	• 23128.EMW33	159	152	213	203	2,1	
	225	85	10,7	4,5	830	1120	2 000	1 100	12,30	• 24128.EAW33	154	152	213	198	2,1	
	250	68	14,18	7	867	1010	3 000	2 200	13,63	• 22228.EAW33	163	154	236	224	3	
	250	68	14,18	7	867	1010	3 000	2 200	14,11	• 22228.EMW33	163	154	236	224	3	
	250	88	12,64	6	1090	1370	2 400	1 700	18,14	• 23228.EMW33	162	154	236	220	3	
	300	102	18,9	9	1470	1720	2 200	1 600	34,01	• 22328.EAW33	181	157	283	261	4	
	300	102	18,9	9	1470	1720	2 200	1 600	34,90	• 22328.EF800	181	157	283	261	4	
	300	102	18,9	9	1470	1720	2 200	1 600	34,90	• 22328.EMW33	181	157	283	261	4	
150	225	56	9,96	4,5	628	893	3 400	2 300	7,56	• 23030.EAW33	167	161	214	207	2,1	
	225	56	9,96	4,5	628	893	3 400	2 300	7,65	• 23030.EMW33	167	161	214	207	2,1	
	225	75	9,3	4	715	1000	2 400	1 600	9,77	• 24030.EAW33	162	161	214	205	2,1	
	250	80	12,63	6	1010	1350	2 600	1 900	15,46	• 23130.EAW33	171	162	238	223	2,1	
	250	80	12,63	6	1010	1350	2 600	1 900	15,64	• 23130.EMW33	171	162	238	223	2,1	
	250	100	10,4	5	1070	1400	2 000	1 100	18,46	• 24130.EAW33	165	162	238	219	2,1	
	270	73	15,33	7	1020	1220	2 800	2 000	17,42	• 22230.EAW33	177	164	256	242	3	
	270	73	15,33	7	1020	1220	2 800	2 000	17,92	• 22230.EMW33	177	164	256	242	3	
	270	96	13,7	6	1280	1620	2 200	1 700	23,40	• 23230.EMW33	174	164	256	237	2,1	
	320	108	19,9	9	1660	1890	2 000	1 500	41,99	• 22330.EF800	188	167	303	279	4	
	320	108	19,9	9	1660	1890	2 000	1 500	41,99	• 22330.EMW33	188	167	303	279	4	
	160	240	60	10,52	5	711	1000	3 000	2 200	9,15	• 23032.EAW33	177	172	229	221	2,1
240		60	10,52	5	711	1000	3 000	2 200	9,22	• 23032.EMW33	177	172	229	221	2,1	
240		80	9,4	4,5	785	1090	2 200	1 500	11,61	• 24032.EAW33	173	172	229	217	2,1	
270		86	13,7	6	1160	1580	2 500	1 800	19,84	• 23132.EAW33	185	172	258	240	2,1	
270		86	13,7	6	1160	1580	2 500	1 800	19,97	• 23132.EMW33	185	172	258	240	2,1	
270		109	11,7	5	1260	1740	1 900	1 000	24,29	• 24132.EAW33	180	172	258	236	2,1	
290		80	16,94	8	1160	1390	2 600	1 900	22,06	• 22232.EAW33	190	174	276	260	3	
290		80	16,94	8	1160	1390	2 600	1 900	22,79	• 22232.EMW33	190	174	276	260	3	
290		104	14,85	7	1470	1890	2 200	1 500	29,42	• 23232.EMW33	186	174	276	259	3	
340		114	20,3	10	1850	2210	1 900	1 400	50,70	• 22332.EF800	205	177	323	296	4	
340		114	20,3	10	1850	2210	1 900	1 400	50,70	• 22332.EMW33	205	177	323	296	4	
170		260	67	11,59	5	869	1240	2 800	2 000	12,67	• 23034.EAW33	190	181	249	238	2,1
	260	67	11,59	5	869	1240	2 800	2 000	12,69	• 23034.EMW33	190	181	249	238	2,1	
	260	90	10,5	5	1010	1430	2 000	1 400	16,19	• 24034.EAW33	184	181	249	233	2,1	
	280	88	13,7	6	1200	1700	2 400	1 700	21,33	• 23134.EAW33	195	182	268	250	2,1	
	280	88	13,7	6	1200	1700	2 400	1 700	21,47	• 23134.EMW33	195	182	268	250	2,1	
	280	109	13,2	6	1310	1840	1 800	850	25,57	• 24134.EAW33	189	182	268	245	2,1	
	310	86	17,98	8	1330	1610	2 500	1 700	28,18	• 22234.EMW33	201	187	293	277	4	
	310	110	13,9	7,5	1210	1830	2 000	1 300	37,00	• 23234.VMW33	199	187	293	264	4	
	360	120	20,25	10	2100	2630	1 700	1 200	60,15	• 22334.EF800	223	187	343	313	4	
	360	120	20,25	10	2100	2630	1 700	1 200	60,15	• 22334.EMW33	223	187	343	313	4	
	180	280	74	13,24	6	1020	1450	2 600	1 900	16,57	• 23036.EAW33	201	191	269	255	2,1
		280	74	13,24	6	1020	1450	2 600	1 900	16,70	• 23036.EMW33	201	191	269	255	2,1
280		100	11,7	5	990	1700	1 800	1 300	21,74	• 24036.EAW33	198	191	269	250	2,1	
300		96	14,85	7	1420	1960	2 200	1 600	26,89	• 23136.EAW33	205	194	286	267	3	
300		96	14,85	7	1420	1960	2 200	1 600	27,21	• 23136.EMW33	205	194	286	267	3	
300		118	14,1	6	1470	2050	1 600	800	31,57	• 24136.EAW33	200	194	286	261	3	
320		86	18	8	1380	1660	2 400	1 700	28,94	• 22236.EMW33	209	197	303	287	4	
320		112	13,9	7,5	1290	2050	2 000	1 300	39,80	• 23236.VMW33	210	197	303	274	4	
380		126	23,1	12	1580	2190	1 500	1 100	67,60	• 22336.VMW33	223	197	363	313	4	
190		290	75	13,24	6	1080	1570	2 400	1 800	17,55	• 23038.EAW33	213	201	279	266	2,1
		290	75	13,24	6	1080	1570	2 400	1 800	17,74	• 23038.EMW33	213	201	279	266	2,1
		290	100	11,59	5	1240	1800	1 700	1 250	22,52	• 24038.EMW33	206	201	279	261	2,1
	320	104	20	7,5	1180	1950	2 000	1 300	34,50	• 23138.VMW33	218	204	306	278	3	
	320	128	14,2	6	1760	2480	1 500	750	40,12	• 24138.EAW33	213	204	306	289	3	

Bearings available with cylindrical or tapered bore (EAK, EMK, EG15K). All clearance variants are available upon request. These bearings can be fitted by means of adapter or withdrawal sleeves (refer to selection guidelines, pages 31-33).

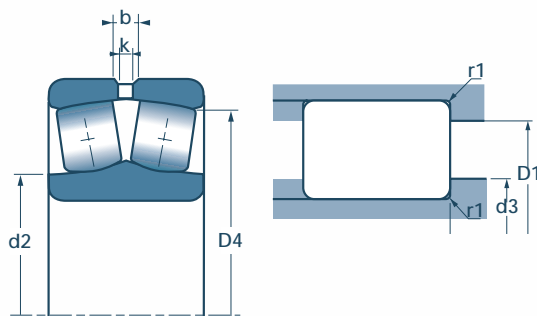

OVERALL DIMENSIONS	BASIC CAPACITIES x 1,000 newton					SPEEDS		WEIGHTS	DESIGNATIONS	FITTING DIMENSIONS					
						rpm		Bore	Bore	mm					
	mm	Dynamic	Static	limit	reference	cylindrical	cylindrical	$d_2 \approx$	$d_3 \text{ min}$	$D_1 \text{ max}$	$D_1 \approx$	$r_1 \text{ max}$			
190	340	92	19,6	9	1540	1870	2 200	1 600	35,31	• 22238.EMW33	222	207	323	305	4
	340	120	16,7	9	1480	2370	1 800	1 200	48,50	23238.VMW33	223	207	323	290	4
	400	132	22,3	12	1830	2650	1 500	1 100	76,40	22338.VMW33	240	210	380	332	5
200	280	60	12,2	6,3	620	1000	2 000	1 700	12,20	23940.VMW33	217	210	283	263	2,1
	310	82	14,28	7	1250	1790	2 200	1 700	22,56	• 23040.EMW33	223	211	299	283	2,1
	310	109	12,67	6	1440	2120	1 500	1 200	29,05	• 24040.EMW33	219	211	299	278	2,1
	340	112	16,7	9	1290	2120	1 700	1 200	42,50	23140.VMW33	230	214	326	294	3
	340	140	16,98	8	2030	2930	1 400	650	51,07	• 24140.EMW33	225	214	326	292	3
	360	98	20	10	1720	2100	2 000	1 500	42,53	• 22240.EMW33	234	217	343	323	4
	360	128	16,7	9	1630	2700	1 600	1 100	58,40	23240.VMW33	238	217	343	307	4
	420	138	22,3	12	1830	2650	1 400	940	99,00	22340.VMW33	302	220	400	346	5
220	300	60	12,2	6,3	665	1120	1 800	1 500	12,30	23944.VMW33	237	230	269	284	2,1
	340	90	15,37	7	1450	2110	1 900	1 500	29,52	• 23044.EMW33	246	233	327	310	3
	340	118	12,2	6,3	1400	2700	1 400	1 100	39,50	24044.VMW33	246	233	327	302	3
	370	120	20,7	9	1540	2600	1 500	1 100	53,00	23144.VMW33	253	237	353	321	4
	370	150	12,2	6,3	1900	3450	1 300	670	65,60	24144.VW33	253	237	353	316	4
	400	108	20,6	11	2100	2690	1 800	1 300	59,47	• 22244.EMW33	264	237	383	358	4
	400	144	20,02	10	2750	3830	1 500	1 100	78,83	• 23244.EMW33	261	237	383	350	4
	460	145	22,3	12	2110	3150	1 300	890	125,00	22344.VMW33	332	240	440	380	5
240	360	92	13,9	7,5	1090	2050	1 500	1 300	33,98	23048.VMW33	270	253	347	324	3
	360	118	12,2	6,3	1500	2900	1 300	1 000	43,60	24048.VMW33	264	253	347	319	3
	400	128	16,7	9	1720	2950	1 400	1 000	67,20	23148.VMW33	276	257	383	348	4
	400	160	12,2	6,3	2120	3900	1 200	610	80,70	24148.VW33	270	257	383	342	4
	440	120	22,3	12	1170	1950	1 600	890	85,00	22248.VMW33	333	257	423	377	4
	440	160	22,3	12	2420	3950	1 300	950	113,18	23248.VMW33	285	257	423	372	4
	500	155	22,3	12	2450	3700	1 300	790	159,00	22348.VMW33	362	260	480	414	5
	260	400	104	16,7	9	1490	2430	1 400	1 200	47,70	23052.VMW33	284	275	385	364
400		140	12,2	6,3	1900	3800	1 200	950	67,20	24052.VMW33	291	275	385	354	4
440		144	16,7	9	2140	3750	1 300	950	93,40	23152.VMW33	302	277	423	380	4
440		180	12,2	6,3	2700	5100	1 100	560	114,00	24152.VW33	294	277	423	373	4
480		174	22,3	12	2700	4450	1 200	850	147,00	23252.VMW33	364	280	460	405	5
280		420	106	16,7	9	1500	2850	1 300	1 100	54,95	23056.VMW33	311	295	405	379
	420	140	12,2	6,3	2000	4000	1 100	900	70,50	24056.VMW33	318	295	405	375	4
	460	146	16,7	9	2240	4050	1 200	900	100,00	23156.VMW33	322	300	440	401	5
	460	180	12,2	6,3	2700	5200	1 000	530	119,00	24156.VW33	315	300	440	396	5
	500	176	22,3	12	2900	4900	1 100	800	157,20	23256.VMW33	327	300	480	426	5
	580	175	22,3	12	3429	5182	950	670	232,00	22356.VMW33	437	306	554	493	6
	300	460	118	16,7	9	1820	3350	1 200	1 000	75,27	23060.VMW33	376	315	445	414
460		160	12,2	6,3	2500	5200	1 000	800	102,00	24060.VMW33	343	315	445	407	4
500		160	16,7	9	2632	4645	1 100	850	134,00	23160.VMW33	346	320	480	435	5
500		200	12,2	6,3	3250	6300	900	490	159,00	24160.VW33	340	320	480	429	5
540		192	22,3	12	3350	5600	1 000	750	200,00	23260.VMW33	415	320	520	459	5
320	480	121	16,7	9	1920	3600	1 100	1 000	79,50	23064.VMW33	355	335	465	433	4
	540	176	22,3	12	3050	5500	1 000	800	171,00	23164.VMW33	369	340	520	468	5
340	520	133	22,3	12	2270	4200	1 000	950	109,00	23068.VMW33	426	358	502	468	5
	580	190	22,3	12	3500	6100	900	750	208,60	23168.VMW33	455	360	560	501	5
	580	243	15	8	4400	8500	800	430	266,00	24168.VW33	383	360	560	485	5
360	540	134	22,3	12	2390	4550	950	900	114,00	23072.VMW33	400	378	522	488	5
	600	192	22,3	12	3681	6683	850	700	231,60	23172.VMW33	475	380	580	522	5
380	560	135	22,3	12	2420	4700	900	850	119,80	23076.VMW33	466	398	542	508	5
400	600	148	22,3	12	2926	5648	800	750	156,00	23080.VMW33	497	418	582	542	5

Bearings available with cylindrical or tapered bore (EAK, EMK, EG15K). All clearance variants are available upon request. These bearings can be fitted by means of adapter or withdrawal sleeves (refer to selection guidelines, pages 31-33).

• Premier





Adapter and withdrawal sleeves: enhancing productivity

The SNR adapter and withdrawal sleeves greatly simplify spherical roller bearing installation/removal and allow you to save significant time in this repetitive operation.

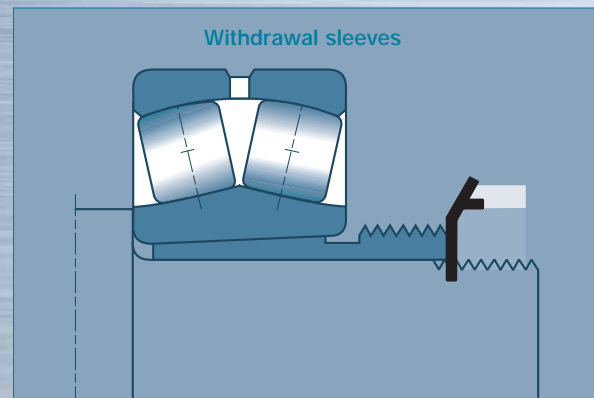
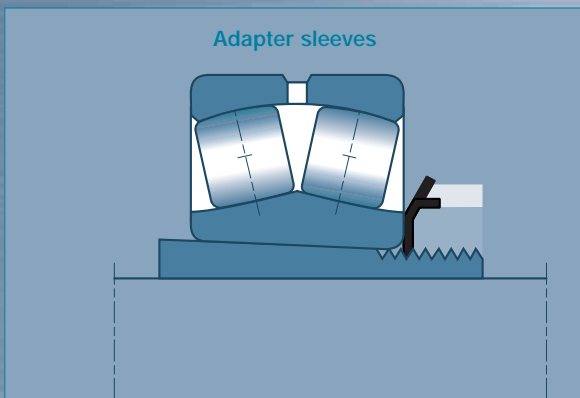

The quality of the assembly and fit is of vital importance to ensure bearing reliability and durability. The sleeves enable bearings with tapered bores to be interference fitted onto cylindrical shafts with wide diameter tolerances.

The taper of the bearing bore is usually 1/12 (K). It is 1/30 for spherical roller bearings (24000 and 24100).

There are 2 main types of sleeves:

- **Adapter sleeves** create the interference fit by pressing the bearing onto the sleeve. They are supplied with a lock washer and nut.
- **Withdrawal sleeves** create the interference fit through insertion of the sleeve into the bearing bore. In addition, these sleeves provide for easy dismantling of the bearing by simply turning the withdrawal nut (to be ordered separately).

To facilitate the fitting and dismantling of large-size bearings (shaft diameters of 200mm and larger), SNR proposes hydraulic adapter and withdrawal sleeves featuring a channel for pressure-injection of oil. The presence of oil reduces friction thereby avoiding damage to the contact surfaces.

This method optimizes bearing fitting and dismantling times, thereby reducing system downtimes.

Whether the bearing is installed using an adapter sleeve or a withdrawal sleeve, it is vital to check that the internal radial clearance of the bearing remains sufficient after tightening the nut (see table on page 30).

For each spherical roller bearing you will find the corresponding adapter and withdrawal sleeve in this catalog (pages 31 to 33).

When fitting the bearing or sleeve, the expansion of the inner ring reduces the internal radial clearance of the bearing. The reduction in clearance enables the tightness of the fit to be determined. It is important to check this. Check carefully that the clearance necessary for the correct functioning of the bearing is maintained.

Reduction of the internal clearance after fitting

Measurement principle

The clearance is measured by sliding thickness gauges between the outer ring and the rollers. With large-size bearings, do not use gauges of thickness exceeding 0.15mm, as they are too rigid to follow the curve of the bearing raceway; use 2 or more thinner gauges to make up the required thickness.

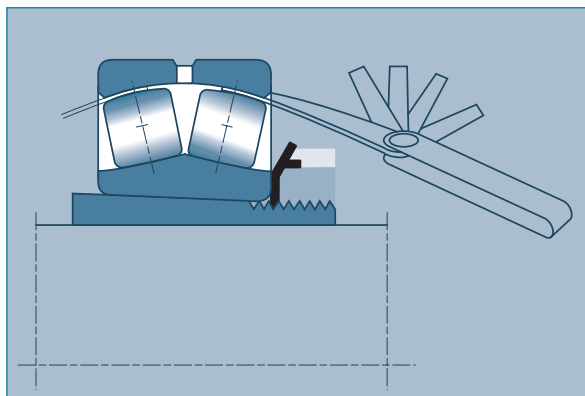

Measurement method

Place the bearing in the vertical position with the rings parallel. Rotate the bearing to position the rollers.

In table in page 30, identify the value of the gauges corresponding to the considered bearing bore and tolerance class (column 3).

Slide the feeler blade between the most unloaded roller and the outer raceway (the upper part of the bearing if it rests on a support, or the lower part of the bearing if the outer ring is unrestrained or suspended).

The tolerance value is between the two indicated gauges (column 3).



Adapter and withdrawal sleeves: enhancing productivity

Verification of clearance reduction

Radial clearance

Tighten the nut until the reduction in internal clearance is within the indicated limits. Check that the final residual clearance, which depends on the original clearance category, at least equals the value indicated (column 3).

Verification of radial clearance on assembly

Bearing bore (mm)		BEFORE FITTING (2)						AFTER FITTING (3)					
		C0		C3		C4		C0		C3		C4	
from	to	Per ISO 5753 (mm)		Per ISO 5753 (mm)		Per ISO 5753 (mm)		Gauge to use		Gauge to use		Gauge to use	
		Min.	Max.	Min.	Max.	Min.	Max.	Yes	No	Yes	No	Yes	No
30	40	0,035	0,050	0,050	0,065	0,065	0,085	2	3	3	4	4	5
40	50	0,045	0,060	0,060	0,080	0,080	0,100	3	4	3	5	4	6
50	65	0,055	0,075	0,075	0,095	0,095	0,120	3	5	4	6	5	7
65	80	0,070	0,095	0,095	0,120	0,120	0,150	4	6	5	7	6	8
80	100	0,080	0,110	0,110	0,140	0,140	0,180	4	6	6	8	7	10
100	120	0,100	0,135	0,135	0,170	0,170	0,220	5	7	7	9	9	12
120	140	0,120	0,160	0,160	0,200	0,200	0,260	8	11	10	13	12	17
140	160	0,130	0,180	0,180	0,230	0,230	0,300	8	12	11	15	14	19
160	180	0,140	0,200	0,200	0,260	0,260	0,340	9	13	12	17	16	21
180	200	0,160	0,220	0,220	0,290	0,290	0,370	11	16	15	20	20	26
200	225	0,180	0,250	0,250	0,320	0,320	0,410	12	17	17	22	22	28
225	250	0,200	0,270	0,270	0,350	0,350	0,450	14	19	18	24	24	31
250	280	0,220	0,300	0,300	0,390	0,390	0,490	15	21	20	27	26	33
280	315	0,240	0,330	0,330	0,430	0,430	0,540	16	23	22	29	29	37
315	355	0,270	0,360	0,360	0,470	0,470	0,590	18	25	24	32	32	40
355	400	0,300	0,400	0,400	0,520	0,520	0,650	20	27	27	36	35	44
400	450	0,330	0,440	0,440	0,570	0,570	0,720	22	30	29	39	38	49
450	500	0,370	0,490	0,490	0,630	0,630	0,790	25	33	33	43	42	54
500	600	0,410	0,540	0,540	0,680	0,680	0,870	28	37	36	46	46	59

Range of installation/withdrawal sleeves, nuts, washers, taper bore bearings (suffix K) and associated wrenches

Shaft	BRG	WRE	S				N(*)				BRG						
			S	N(*)	BRG	S	N(*)	BRG	S	N(*)	BRG	S	N(*)	BRG			
17	20	15/35	H304	KM4													
20	25	35/50	H305	KM5	21305	22205	H2305	KM5									
25	30	35/50	H306	KM6	21306	22206	H2306	KM6									
30	35	50/80	H307	KM7	21307	22207	H2307	KM7									
35	40	50/80	H308	KM8	21308	22208	H2308	KM8	22308								
40	45	50/80	H309	KM9	21309	22209	H2309	KM9	22309								
45	50	50/80	H310	KM10	21310	22210	H2310	KM10	22310								
50	55	50/80	H311	KM11	21311	22211	H2311	KM11	22311								
55	60	50/80	H312	KM12	21312	22212	H2312	KM12	22312								
60	65	80/120	H313	KM13	21313	22213	H2313	KM13	22313								
65	70	80/120	H314	KM14	21314	22214	H2314	KM14	22314								
70	75	80/120	H315	KM15	21315	22215	H2315	KM15	22315								
75	80	80/120	H316	KM16	21316	22216	H2316	KM16	22316								
80	85	80/120	H317	KM17	21317	22217	H2317	KM17	22317								
85	90	120/180	H318	KM18	21318	22218	H2318	KM18	22318								
90	95	120/180	H319	KM19		22219	H2319	KM19	22319								
95	100	120/180	H320	KM20		22220	H2320	KM20	22320	23220		H3120	KM20		23120		
100	110	120/180	H322	KM22		22222	23022	H2322	KM22	22322	23222		H3122	KM22		23122	
110	120	120/180					H2324	KM24	22324	23224	H3024	KML24	23024	H3124	KM24	22224	23124
115	130	120/180					H2326	KM26	22326	23226	H3026	KML26	23026	H3126	KM26	22226	23126
125	140						H2328	KM28	22328	23228	H3028	KML28	23028	H3128	KM28	22228	23128
135	150						H2330	KM30	22330	23230	H3030	KML30	23030	H3130	KM30	22230	23130
140	160						H2332	KM32	22332	23232	H3032	KML32	23032	H3132	KM32	22232	23132
150	170						H2334	KM34	22334	23234	H3034	KML34	23034	H3134	KM34	22234	23134
160	180						H2336	KM36	22336	23236	H3036	KML36	23036	H3136	KM36	22236	23136
170	190						H2338	KM38	22338	23238	H3038	KML38	23038	H3138	KM38	22238	23138
180	200						H2340	KM40	22340	23240	H3040	KML40	23040	H3140	KM40	22240	23140
200	220						H2344H	HM44T	22344	23244	H3044H	HM3044	23044	H3144	HM44T	22244	23144
220	240						H2348H	HM48T	22348	23248	H3048H	HM3048	23048	H3148H	HM48T		23148
240	260						H2352H	HM52T		23252	H3052H	HM3052	23052	H3152H	HM52T		23152
260	280						H2356H	HM56T	22356	23256	H3056H	HM3056	23056	H3156H	HM56T		23156
280	300										H3060H	HM3060	23060	H3160H	HM3160		23160
300	320										H3064H	HM3064	23064	H3164H	HM3164		23164
320	340										H3068H	HM3068	23068	H3168H	HM3168		23168
340	360										H3072H	HM3072	23072	H3172H	HM3172		23172
360	380										H3076H	HM3076	23076				
380	400										H3080H	HM3080	23080				

BRG : Taper bore bearing (suffix K)
WRE : Corresponding spanner wrench
S : Sleeve
N : Nut

N(*) : nut KMx with washer MBx
nut KMLxx with washer MBLxx
nut HMxxT with MBxx
nut HMxxxx with MSxxxx

e.g.: KM8 with MB8
KML34 with MBL34
HM44T with MB44
HM3056 with MS3056



Adapter and withdrawal sleeves: enhancing productivity

Range of installation/withdrawal sleeves, nuts, washers, taper bore bearings (suffix K) and associated wrenches

REMOVAL	Shaft	BRG	WRE	S	N	BRG	S	N	BRG	S	N	BRG	S	N	BRG	
	17	20														
	20	25														
	25	30														
	30	35														
	35	40	50/80	AH308	KM9	21308	22208				AH2308	KM9	22308			
	40	45	50/80	AH309	KM10	21309	22209				AH2309	KM10	22309			
	45	50	50/80	AHX310	KM11	21310	22210				AHX2310	KM11	22310			
	50	55	50/80	AHX311	KM12	21311	22211				AHX2311	KM12	22311			
	55	60	50/80	AHX312	KM13	21312	22212				AHX2312	KM13	22312			
	60	65	80/120	AH313G	KM14	21313	22213				AH2313G	KM14	22313			
	65	70	80/120	AH314G	KM15	21314	22214				AHX2314G	KM15	22314			
	70	75	80/120	AH315G	KM16	21315	22215				AHX2315G	KM16	22315			
	75	80	80/120	AH316	KM18	21316	22216				AHX2316	KM18	22316			
	80	85	80/120	AHX317	KM19	21317	22217				AHX2317	KM19	22317			
	85	90	120/180	AHX318	KM20	21318	22218				AHX2318	KM20	22318			
	90	95	120/180	AHX319	KM21		22219				AHX2319	KM21	22319			
	95	100	120/180	AHX320	KM22		22220				AHX2320	KM22	22320			
	105	110	120/180								AHX2322G	KM24	22322			
	115	120	120/180								AHX2324G	KM26	22324	AHX3024	KM26	23024
125	130	120/180								AHX2326G	KM28	22326	AHX3026	KM28	23026	
135	140									AHX2328G	KM30	22328	AHX3028	KM30	23028	
145	150									AHX2330G	KM32	22330	AHX3030	KM32	23030	
150	160									AH2332G	KM34	22332	AH3032	KM34	23032	
160	170									AH2334G	KM36	22334	AH3034	KM36	23034	
170	180						AH2236G	KM38	22236	AH2336G	KM38	22336	AH3036	KM38	23036	
180	190						AH2238G	KM40	22238	AH2338G	KM40	22338	AH3038G	KM40	23038	
190	200						AH2240	HM44T	22240	AH2340	HM44T	22340	AH3040G	HM44T	23040	
200	220						AOH2244	HM48T	22244	AOH2344	HM48T	22344	23244	AOH3044G	HM46T	23044
220	240									AOH2348	HM52T		23248	AOH3048	HM52T	23048
240	260									AOH2352G	HM56T		23252	AOH3052	HM56T	23052
260	280									AOH2356G	HM3160		23256	AOH3056	HM3060	23056
280	300													AOH3060	HM3064	23060
300	320													AOH3064G	HM3068	23064
320	340													AOH3068G	HM3072	23068
340	360													AOH3072G	HM3076	23072
360	380													AOH3076G	HM3080	23076
380	400													AOH3080G	HM3084	23080

Note: For one same shaft diameter, the sleeves with suffix "G" do not feature the same nuts as sleeves without suffix "G".

Maintenance: installation-removal Quality, for a longer service life

Know-how and cleanliness are essential factors for bearing installation and removal. SNR proposes suitable tools, tailored to your needs to optimize bearing service life.

- ① - Induction heating devices: Fast Therm 20/35/150/300/600/1000
- ② - Installation kit
- ③ - Wrench for standard and precision locknuts
- ④ - Hydraulic extractor, 10T
- ⑤ - Kevlar®, heat-resistant gloves



①



②



③



④



⑤



You will find all our products in
SNR's Maintenance catalogue: 64 pages of solutions.

- Lubrication
- Installation & removal
- Measurement & monitoring
- Vibratory analysis, training, ...



Maintenance: Lubrication Your bearings' life insurance

To maintain all bearing properties, suitable lubrication is a constant requirement.

Lubrication tips

Obtaining satisfactory lubrication as early as the first turns of the bearing is a prerequisite.

- Grease lubrication

It is recommended to use an SNR syringe or lubrication gun to inject grease under pressure:

- underneath the cage and between the rollers,
- underneath the rollers,

- then, rotate the rollers until the grease appears at the upper part, guaranteeing adequate lubricant film between rollers and races.

- Oil lubrication

Use a suitable oil, in sufficient quantity. The bearing must be « splash » - lubricated in oil.

Relubrication

When bearings are operated at high speeds and temperatures, relubrication is required. Grease can be introduced via the groove and the 3 lubrication holes in the outer ring. The bearing must turn during

lubrication to obtain suitable grease distribution. It is advisable to use the same grease as that used for first greasing.

SNR products tailored to your needs

① - SNR-LUB grease range, particularly suitable for spherical roller bearings:

- **SNR-LUB EP grease:** extreme pressure: high loads, normal speed.
- **SNR-LUB VX grease:** high loads, low speeds: recommended for vibratory applications.
- **SNR-LUB FV grease:** low speeds.

② - Special grease gun for bearings.

③ - Automatic lubricator.





Monitoring, SNR Services: follow the life cycle of each bearing

Continuous and/or periodic vibratory monitoring

90% of the premature bearing failures are caused by external factors. Therefore, it is recommended to check the bearing state and monitor their evolution. The periodic/continuous inspection process is intended to detect and evaluate incipient failures in order to plan bearing replacement. The whole series of characteristic indicators must be set, depending on the concerned equipment: noise level, lubrication, bearing temperature in the application, aspect according to the pollution level, the dampness level, ...

In partnership with the **01dB-Metravib** company, SNR offers a range of monitoring devices to analyze the environmental constraints which are detrimental to correct operation of your bearings and facilities.

Our vibratory application expertise services will allow you to define:

- the monitoring methods and inspection means,
- the inspection periods,
- the organization to be put in place,
- the formal result recording process.



The laser sighting thermometer

For bearing temperature monitoring in operation.

Calibrated thickness gauges

Internal radial play measurement in spherical roller bearings and cylindrical bearings.



| Bearing installation or removal operations

Installing or removing a bearing is not a simple process. If you do not have the suitable facilities and means, or the available personnel, SNR proposes an alternative. Our work teams, especially trained by SNR, are comprised of reliable, professional agents. They will supervise your fitting-extraction operations or even perform them upon your request, providing you with optimised solutions. The services are tailored to each type of application and each sector: paper mills, iron & steel, quarries, cement works, agri-food, chair lifts and ski lifts, etc.



| Shaft alignment

Misalignment generates loads and vibrations which in turn cause premature wear on the bearings, but also to the couplings, packings, seals, ... The abnormal loads caused by misalignment generally result in an increased energy consumption and have a direct effect on the maintenance costs and on your production tool's availability rating.

Entrust the SNR experts with your shaft alignment operations: a reliable partner is at your disposal.

| Bearing expertise

Bearing expertise allows better control of the actual work conditions and clear comprehension of the detrimental processes. It takes into account the environment (pollution, humidity, vibrations, etc.), the installation quality, the lubrication and the nature of the imposed loads.

This investigation also allows determination of the nature of the monitoring process to be implemented, as well as the need for on-going maintenance.

We will provide a complete report as well as technical tips in order to improve your bearing operations.

How to have your bearings analyzed

The bearing must be shipped to us **uncleaned**, together with an analysis request sheet, available from your SNR contact or dealer.

Please provide maximum information concerning your equipment operation and environment, to allow us to determine the failure causes.





Spherical roller bearings: choose Premier to benefit from SNR's entire expertise

Optimize each product to achieve the greatest performance possible, without increasing prices: this is a leading manufacturer's mission. The Premier quality approach essentially addresses the family of spherical bearings and allows us to appreciably optimize our product range in the four main categories effecting reliability and service life: steel selection, internal geometry, lubrication / sealing, and finishing.

